

Euro Pillar Lite

Cat. No. EPIL

Cat. No. EPIL/R

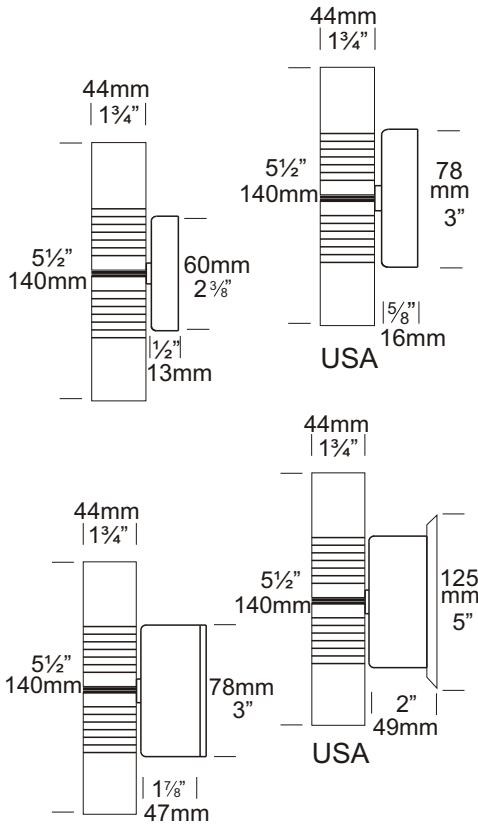

The Euro Pillar Lite illuminates both upwards and downwards giving columns, gateways, pillars and entrances a dramatic effect. Hunza Euro fixtures use miniature MR11 lamps to achieve a contemporary, discreet appearance but are still able to provide excellent illumination.

The Retro™ is a 110/240-12 ac mains option suited to an installation where mounting a transformer is a problem, e.g. a brick wall where there is only the cable protruding out of the wall and it is not an option to recess the transformer or when replacing an existing light fitting. The base size increases in size to accommodate the encapsulated IP66 dimmable transformer.

Ordering Information

Luminaire Type	Material	Accessories
EPIL - Euro Pillar Lite	COP - Copper SS - 316 Stainless Steel	CJK150 - Cable Joint Kit /R- Retro™ Transformer 110/240-12 volt LENSEURF - Frosted Lens WBAP - Wall Box Adaptor Plate (12 volt Luminaire)
		For LED options, refer to page 10.4.5 (2 watt MR11) or http://hunza.co.nz/l.html



Ordering Example: EPIL COP - Euro Pillar Lite in Copper

EPIL/R SS - Euro Pillar Lite Retro™ in 316 Stainless Steel

LENSEURF - Frosted Lens
(Accessories ordered separately)

HUNZA™ PURE OUTDOOR LIGHTING

HUNZA FACTORY
130 Felton Mathew Ave
Glen Innes
Auckland 1072
New Zealand

Ph: 64-9-528 9471
Fax: 64-9-528 9361
hunza@hunza.co.nz
www.hunza.co.nz

INTERNATIONAL CONTACTS:
www.hunza.co.nz/contacts.php

Specifications may change without notice.
Manufactured in New Zealand.
© 2011 Hunza Holdings Ltd.

Ver 1.4

Luminaire Construction

CNC machined from one of the following metals:

Body:

Copper 45.4mm (1¾") rod.

Base:

Copper hand spun 2mm (1/8")

Body:

316 Stainless Steel 45.4mm (1¾") rod.

Base:

Investment cast and CNC machined.

Mounting

12 volt: the luminaire is mounted to the wall using two 316 stainless screws through a shallow base, 16mm (5/8") in depth. A Wall Box Adaptor Plate is available as an accessory to fit 3.0 and 4.0 junction boxes for USA/Canada.

Retro™ luminaire (110/240-12 volt): a mounting plate is fixed to the wall using two screws and the luminaire is fitted to the mounting plate.

Features

Lens:

6mm (¼") clear flush fit shatter resistant glass with Hex Cell Louvre for glare control. Lifetime Warranty.

Gaskets:

Silicone, iron impregnated 220°C (428°F).

Lamp Holders:

GU4 - 350°C (662°F) ceramic multi contact lamp holder with 180°C (356°F) silicone cables.

Accessories:

Cable Joint Kit (Cat. CJK150)
Not approved for USA/Canada.

Frost Lens (Cat. LENSEURF).

Retro™ transformer 110/240-12 volt (Cat. /R).

Wall Box Adaptor Plate (Cat. WBAP 12 volt luminaires USA/Canada).

Standards

IP66 AS/NZS 61046



UL1838

Luminaire Weight

12 volt

Cop .660kg (1lb 7oz)

SS .710kg (1lb 9oz)

Retro™

Cop 1.175kg (2lb 9oz)

SS 1.245kg (2lb 11oz)

Power Supply

HUNZA™ Inground or Wall Mount
Transformer: not included.

USA and Canada:

HUNZA™ Wall Mount Transformer:
not included

RETRO

HUNZA™ 110/240-12 volt ac potted electronic transformer built into the Retro™ base. Dimmable with a suitable a dimmer.

Lamp Type

MR11 GU4 - 2 x 20 watt lamp max
LED - Refer to previous page.

USA and Canada:

MR11 GU4 - 2 x 10 watt lamp max.
LED - Refer to previous page.

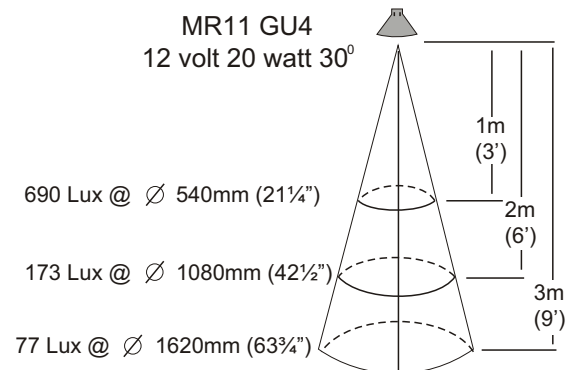
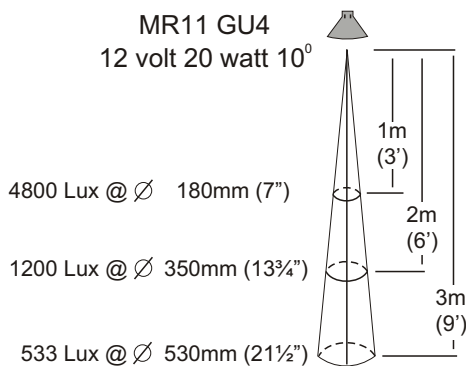

HUNZA™ PURE
OUTDOOR
LIGHTING

HUNZA FACTORY
130 Felton Mathew Ave
Glen Innes
Auckland 1072
New Zealand

Ph: 64-9-528 9471
Fax: 64-9-528 9361
hunza@hunza.co.nz
www.hunza.co.nz

INTERNATIONAL CONTACTS:
www.hunza.co.nz/contacts.php

Specifications may change without notice.
Manufactured in New Zealand.
© 2011 Hunza Holdings Ltd.

Ver 1.4