

Floor Lite Dark Square Lighter

Cat. No. FLDKSQ
Cat. No. FLDKSQGU

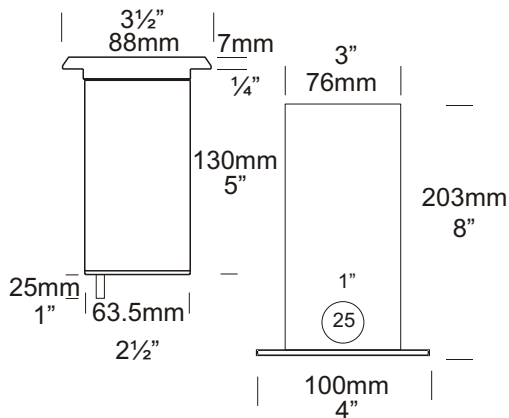

The Floor Lite Dark Square Lighter has a lamp that is recessed 50mm (2") down in to the body of the luminaire. Along with a hex cell louvre and a matt black interior, the luminaire has superior glare control. The Dark Lighter Square version of the Floor Lite has an extremely low profile (3mm) and can be walked upon with out damaging the luminaire. There are two flange designs: Louvre (45 degree angle), Spot and is supplied with a mounting canister.



Floor Canister 200
(Supplied with Luminaire)

A GU10 version of this luminaire is also available for line voltage lamps.

Ordering Information

Luminaire Type	Material	Accessories
FLDKSQ - Floor Lite	SS - 316 Stainless Steel	CJK150 - Cable Joint Kit Canss - 316 Stainless Steel Canister LENSSTEPF - Frost Lens Dkcan - Deck Canister FLcan200 - Floor Lite Canister GU - GU10 Option HCL - Hex Cell Adaptor
Flange		
LU - Louvre SP - Spot		



Ordering Example: FLDKSPSQ SS - Floor Lite Dark Square Lighter Spot in 316 Stainless Steel
FLDKSPSQGU SS - Floor Lite Dark Square Lighter Spot GU10 in 316 Stainless Steel

(Accessories ordered separately)

HUNZA™ PURE OUTDOOR LIGHTING

HUNZA FACTORY
130 Felton Mathew Ave
Glen Innes
Auckland 1072
New Zealand

Ph: 64-9-528 9471
Fax: 64-9-528 9361
hunza@hunza.co.nz
www.hunza.co.nz

INTERNATIONAL CONTACTS:
www.hunza.co.nz/contacts.php

Specifications may change without notice.
Manufactured in New Zealand.
© 2011 Hunza Holdings Ltd.

Ver 1.4

Luminaire Construction

CNC machined from:

Body:

316 Stainless Steel 63.5mm (2½") x 9mm (1/3"). End cap - solid 316 stainless steel 63.5mm (2½") rod.

Flange:

316 Stainless Steel 90mm (3½").

Mounting

The luminaire is pushed into the canister and is held by two silicone "O" rings: Canss: Cast into concrete, brick, concrete block, etc.

Dkcan: mounted into wooden decks, wooden frames, etc.

Features

Lens:

10mm (3/8") clear tempered shatter resistant glass.

Lifetime Warranty.

Gasket:

Silicone, iron impregnated 220°C (428°F).

Lamp Holders:

GU5.3 & GU10 - 350°C (662°F) ceramic multi contact lamp holder with 250°C (480°F) teflon cables.

Accessories:

Cable Joint Kit (Cat. CJK150)

Not approved for USA /Canada.

Deck Canister (Cat. Dkcan).

Frosted Lens (Cat. LENSSTPEPF).

Floor Canister 200 (Cat. FLcan200).

316 Stainless Canister for use in lime stone etc. (Cat. Canss).

GU10 Option (Cat. GU).

Hex Cell Louvre Adaptor (Cat. HCL)

(Note: Supplied as standard for USA/Canada).

Standards

EN60598

IP68



UL1838

Luminaire Weight

SS 1.630kg (3lb 10oz)

Power Supply

HUNZA™ Inground or Wall Mount
Transformer: not included.

HUNZA™ Wall Mount Transformer:
not included.

Luminaire: supplied with

MR16 GU5.3 - 20 watt lamp max.
GU10 - GU10 25 or 35 watt lamp max.

USA and Canada:

MR16 GU5.3 20 watt lamp max.
GU10 Halogen - Lamp not supplied

MR16 ESX GU5.3
12 volt 20 watt 10°

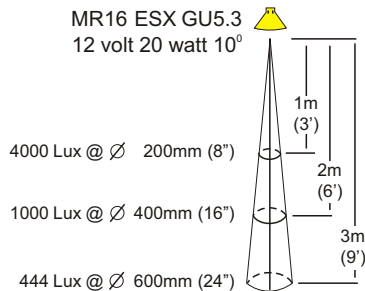

MR16 BAB GU5.3
12 volt 20 watt 38°

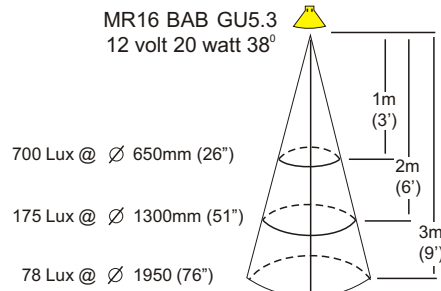

MR16 GU5.3
12 volt 20 watt 60°

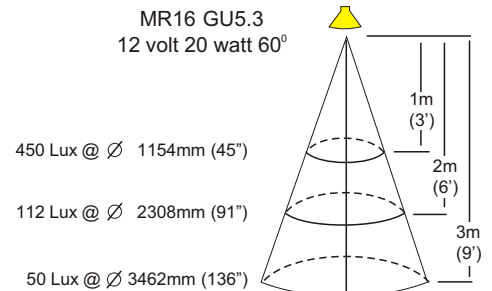

These diagrams refer to the Spot Lite Flange (D) only.

HUNZA™ PURE
OUTDOOR
LIGHTING

HUNZA FACTORY
130 Felton Mathew Ave
Glen Innes
Auckland 1072
New Zealand

Ph: 64-9-528 9471
Fax: 64-9-528 9361
hunza@hunza.co.nz
www.hunza.co.nz

INTERNATIONAL CONTACTS:
www.hunza.co.nz/contacts.php

Specifications may change without notice.
Manufactured in New Zealand.
© 2011 Hunza Holdings Ltd.

Ver 1.4